

INSTRUCTIONS-PARTS LIST



308-535

Rev A

This manual contains **IMPORTANT**
WARNINGS and **INSTRUCTIONS**
READ AND RETAIN FOR REFERENCE

HYDRA-CLEAN® 2510, 3009 Pressure Washers

HYDRA-CLEAN® 2510
P/N 800-901, Series A

2500 psi (172 bar) OPERATING PRESSURE
2900 psi (200 bar) MAXIMUM WORKING PRESSURE

HYDRA-CLEAN® 3009
P/N 800-900, Series A

3000 psi (207 bar) OPERATING PRESSURE
3400 psi (234 bar) MAXIMUM WORKING PRESSURE

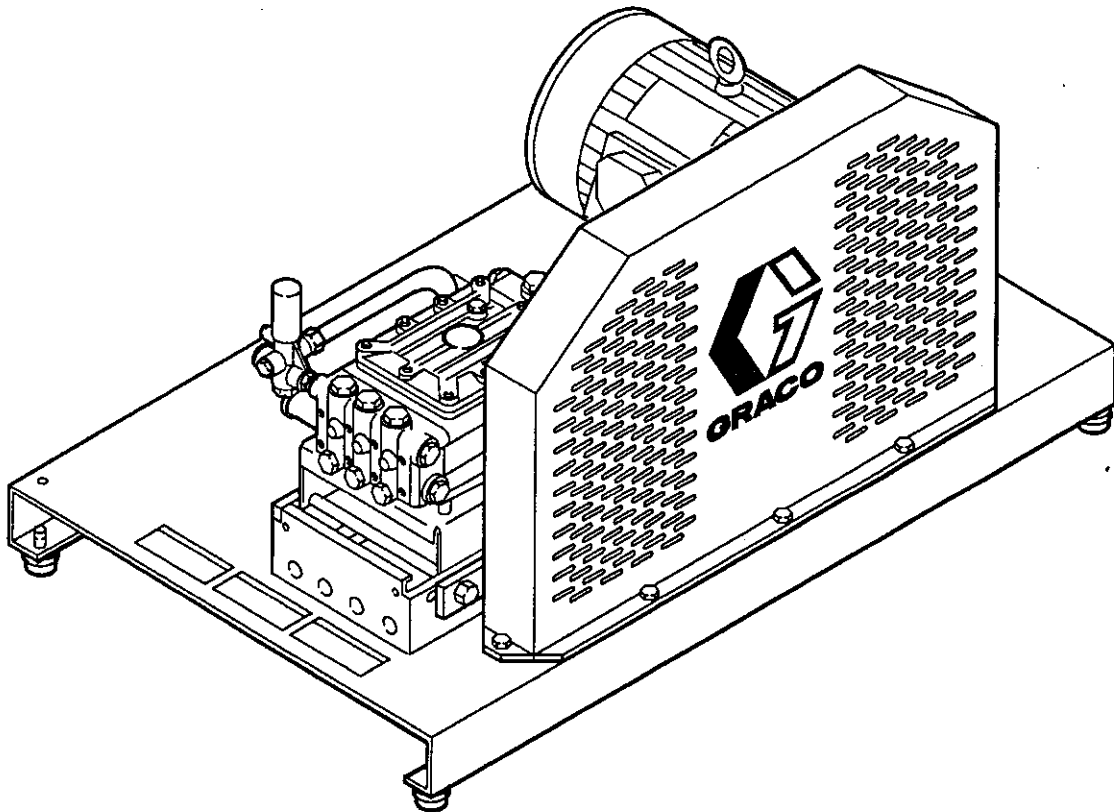

Water supply tank, gun & wand assembly, hose assembly and motor starter are not included.

GRACO INC. P.O. Box 1441 MINNEAPOLIS, MN 55440-1441

©COPYRIGHT 1991, GRACO INC.

WARNING

**HIGH PRESSURE SPRAY CAN CAUSE SERIOUS INJURY.
FOR PROFESSIONAL USE ONLY. OBSERVE ALL WARNINGS.**

Read and understand all instruction manuals before operating equipment.

FLUID INJECTION HAZARD

General Safety

This pressure washer generates very high fluid pressure. Spray from the gun, leaks or ruptured components can inject fluid through your skin and into your body and cause extremely serious bodily injury including the need for amputation. Also, fluid injected or splashed into the eyes or on the skin can cause serious damage.

NEVER point the spray gun or wand at anyone or at any part of the body. *NEVER* put hand or fingers over the spray tip.

ALWAYS follow the **Pressure Relief Procedure**, before cleaning or servicing any part of the sprayer.

NEVER try to stop or deflect leaks with your hand or body.

Be sure equipment safety devices are operating properly before each use.

Medical Treatment

If any fluid appears to penetrate your skin, get **EMERGENCY MEDICAL TREATMENT AT ONCE. DO NOT TREAT AS A SIMPLE CUT.** Tell the doctor exactly what fluid was injected.

NOTE TO PHYSICIAN: *Injection in the skin is a traumatic injury. It is important to treat the injury surgically as soon as possible. Do not delay treatment to research toxicity. Toxicity is a concern with some exotic coatings injected directly into the bloodstream. Consultation with a plastic surgeon or reconstructive hand surgeon may be advisable.*

Pressure Relief Procedure

To reduce the risk of serious bodily injury, including fluid injection and splashing in the eyes or on the skin, always follow this procedure whenever you stop spraying for more than 10 minutes, when shutting down, and before checking or repairing any part of the system.

1. Engage the trigger safety latch.
2. Turn the sprayer off.
3. Disconnect the electrical supply.
4. Shut off the water supply.
5. Disengage the trigger safety latch and trigger the gun to relieve pressure, and then engage the trigger safety latch again.
6. Before long-term (overnight) storage, disconnect the water supply and disconnect the electricity.

Spray Gun Safety Devices

Be sure all gun safety devices are operating properly before each use. Do not remove or modify any part of the gun; this can cause a malfunction and result in serious bodily injury.

SAFETY LATCH: Whenever you stop spraying for a moment, always set the gun safety latch in the engaged or "safe" position, making the gun inoperative. Failure to properly set the safety latch can result in accidental triggering of the gun.

SPRAY TIP SAFETY: Use extreme caution when cleaning or changing spray tips. If a spray tip clogs while spraying, engage the gun safety latch immediately. *ALWAYS* follow the **Pressure Relief Procedure** and then remove the spray tip to clean it.

GROUNDING INSTRUCTIONS

This product must be grounded. If it should malfunction or break down, grounding provides a path of least resistance for electric current to reduce the risk of electric shock. This equipment is equipped with a cord having an equipment-grounding conductor and a grounding plug. The plug must be plugged into an appropriate outlet that is properly installed and grounded in accordance with all local codes and ordinances.

DANGER

Improper connection of the equipment-grounding conductor can result in the risk of electrocution. Check with a qualified electrician or service person if you are in doubt as to whether the outlet is properly grounded.

GROUND FAULT CIRCUIT INTERRUPTER PROTECTION

To comply with the National Electrical Code (NFPA 70) and to provide additional protection from the risk of electric shock, connect this pressure washer to a circuit that is protected by a ground-fault circuit-interrupter (GFCI).

EQUIPMENT MISUSE HAZARD

General Safety

Any misuse of the pressure washer or accessories, such as overpressurizing, modifying parts, using incompatible chemicals and fluids, or using worn or damaged parts, can cause them to rupture and result in fluid injection, splashing in the eyes or on the skin, or other serious bodily injury, fire, explosion or property damage.

NEVER alter or modify any part of this equipment; doing so could cause it to malfunction.

CHECK all spray equipment regularly and repair or replace worn or damaged parts immediately.

ALWAYS wear protective eyewear and appropriate clothing. If using a chemical injector, read and follow the chemical manufacturer's literature for recommendations on additional protective equipment, such as a respirator.

System Pressure

This sprayer can develop high operating pressure. Be sure that all spray equipment and accessories are rated to withstand the maximum working pressure of this sprayer. *DO NOT* exceed the maximum working pressure of any component or accessory used in the system.

Chemical Compatibility

BE SURE that all chemicals used in the chemical injector are compatible with the wetted parts of the hose, gun, wand and tip, as given in the Technical Data (inside back cover). Always read the chemical manufacturer's literature before using any chemical in this pressure washer.

HOSE SAFETY

High pressure fluid in the hoses can be very dangerous. If the hose develops a leak, split or rupture due to any kind of wear, damage or misuse, the high pressure spray emitted from it can cause a fluid injection injury or other serious bodily injury or property damage.

ALL FLUID HOSES MUST HAVE STRAIN RELIEFS ON BOTH ENDS. The strain reliefs help protect the hose from kinks or bends at or close to the coupling, which can result in hose rupture.

TIGHTEN all fluid connections securely before each use. High pressure fluid can dislodge a loose coupling or allow high pressure spray to be emitted from the coupling.

NEVER use a damaged hose. Before each use, check entire hose for cuts, leaks, abrasion, bulging cover, or damage or movement of the hose couplings. If any of these conditions exist, replace the hose immediately. **DO NOT** try to recouple high pressure hose or mend it with tape or any other device. A repaired hose cannot contain the high pressure fluid.

HANDLE AND ROUTE HOSES CAREFULLY. Do not pull on hoses to move the pressure washer. Do not use chemicals which are not compatible with the inner tube and cover of the hose. **DO NOT** expose Graco hose to temperatures above 200° F (93° C) or below -40° F (-40° C).

MOVING PARTS HAZARD

Moving parts can pinch or amputate fingers or other body parts. **KEEP CLEAR** of moving parts when starting or operating the pressure washer.

NEVER operate the pressure washer without all guards and interlocks installed and functioning. Follow the

Pressure Relief Procedure before checking or servicing the pressure washer to prevent discharging high pressure fluid from the gun.

TERMS

WARNING or DANGER: Alerts user to avoid or correct conditions that could cause bodily injury.

CAUTION: Alerts user to avoid or correct conditions that could cause damage to the equipment.

NOTE: Identifies helpful procedures and information.

IMPORTANT

United States Government safety standards have been adopted under the Occupational Safety and Health Act. These standards—particularly the General Standards, Part 1910, and the Construction Standards, Part 1926—should be consulted.

INSTALLATION

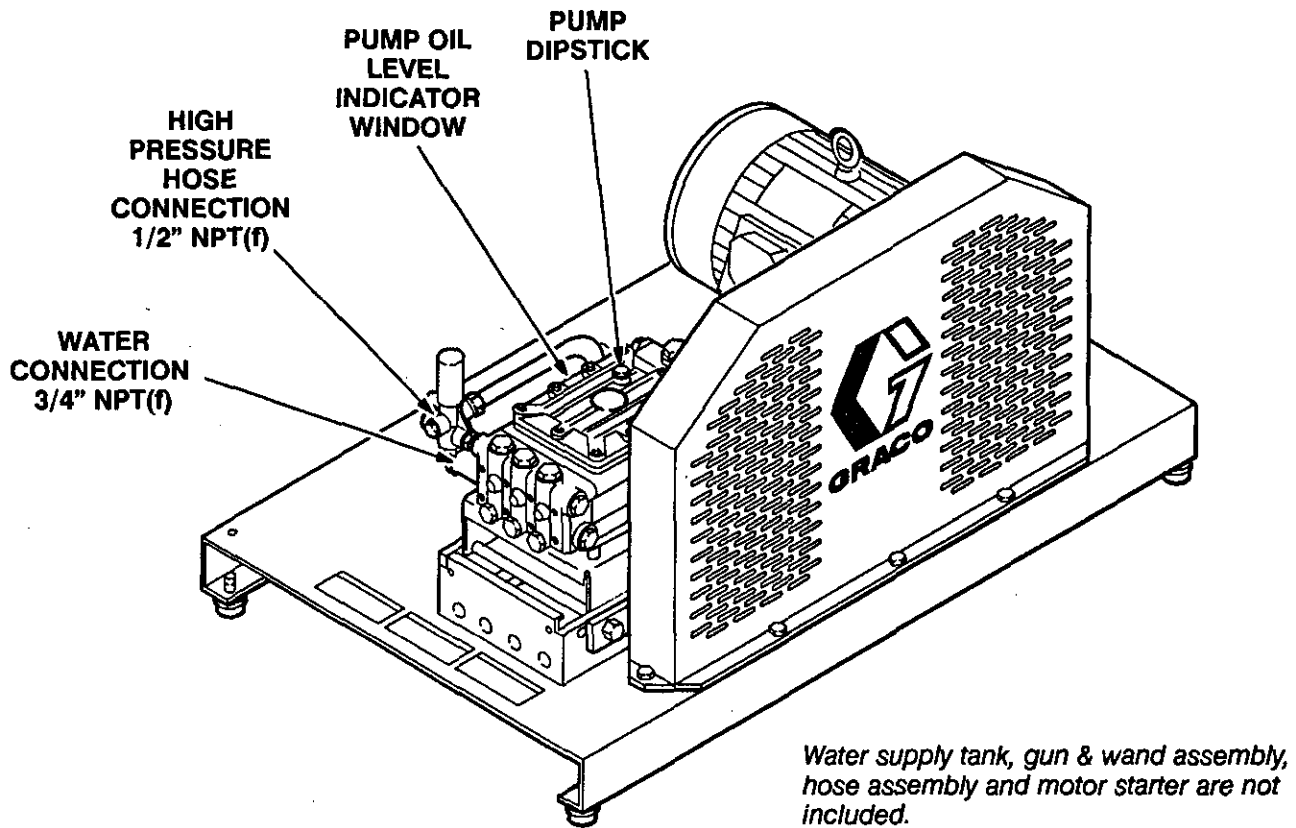

Figure 1

Check for Shipping Damage

Check the unit for any damage that may have occurred in shipping. **Notify the carrier immediately if there is any damage.**

Set Up

Before connecting the unit, be sure the electrical service matches the specification in Technical Data (inside back cover) and the voltage label on the unit. With the unit off, connect the power supply cord to a grounded, GFCI-protected circuit.

If you are using a downstream chemical injector, install it between the pump unloader and the high pressure hose.

Connect the high pressure hose between the pump outlet and the gun inlet.

CAUTION

Up to 100 ft (30 m) of high pressure hose may be used. Longer hoses may affect sprayer performance, and chemical injector performance, if used.

Install the appropriate spray tip on the wand. See Installing and Changing Spray Tips. If you are using a sandblaster kit, see its separate manual for installation instructions.

Connect to Water Supply

CAUTION

Before attaching to the water supply, check your local plumbing code regarding cross-connection to the water supply.

A backflow preventer P/N 801-133 is available to prevent backflow of contaminated water into the fresh water supply. Install it upstream from the pump.

Install a regulating water valve, P/N 800-258, if inlet water pressure is over 60 psi (4.1 bar).

Do not exceed 160° F (70° C) inlet water temperature.

NOTE: The water source for the unit *must* have a minimum 55 gallon float valve controlled water holding tank.

STARTUP

Use this procedure whenever starting the pressure washer to help insure that the unit is ready to operate and starting is done safely.

1. Check the oil level.

Pump: Add SAE 20 or 30 weight non-detergent oil as necessary.

2. Turn on the water supply.

CAUTION

Never run the unit dry. Costly damage to the pump will result. Always be sure the water supply is completely turned on before operating.

3. Trigger the gun until water sprays from the tip indicating that the air is purged from the system.
4. Start the unit.
5. **ALWAYS** engage the gun's trigger safety latch whenever you stop spraying, even for a moment to reduce the risk of fluid injection or splashing in the eyes or on the skin if the gun is bumped or triggered accidentally.

6. **ALWAYS** observe the following **CAUTIONS** to avoid costly damage to the pressure washer.

CAUTION

DO NOT allow the pressure washer to idle for more than 10 minutes. Doing so may cause the recirculating water to overheat and seriously damage the pump. Turn off the pressure washer if it will not be spraying or cleaning at least every 10 minutes. If heated inlet water is used, reduce this time further.

DO NOT run the pump dry, which will quickly damage the pump. Be sure the water supply is fully turned on before starting the pump.

DO NOT pump caustic materials; such materials may corrode the pump components.

7. See the chemical injector or sandblaster kit manual for detailed cleaning information if these accessories are used.

Trigger Safety Latch

WARNING

To reduce the risk of serious bodily injury, including fluid injection, splashing in the eyes or on the skin, **ALWAYS** engage the trigger safety latch whenever spraying stops, even for a moment.

In the engaged position, the trigger safety latch prevents the gun from being triggered accidentally by hand or if it is dropped or bumped. Be sure the latch is pushed fully down when engaging it or it cannot prevent the gun from being triggered. See Figure 2.

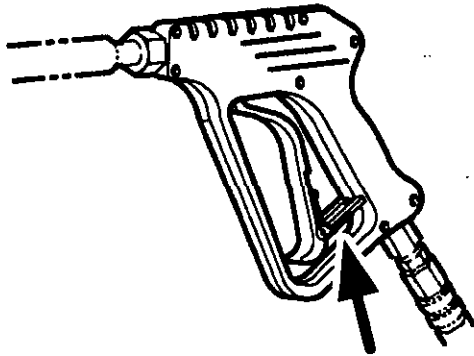

TRIGGER SAFETY LATCH SHOWN ENGAGED

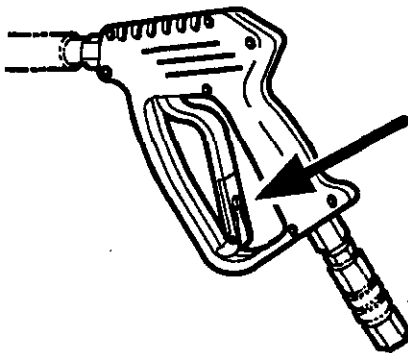

TRIGGER SAFETY LATCH SHOWN DISENGAGED

Figure 2

Installing and Changing Spray Tips

WARNING

To reduce the risk of serious bodily injury, including fluid injection or splashing in the eyes or onto the skin, use extreme caution when changing spray tips. **ALWAYS** follow the procedure below.

1. Follow the **Pressure Relief Procedure**.
2. Point the gun and wand away from yourself and anyone else.
3. Without holding your hand over the spray tip (A), pull back the quick coupler ring (B), remove the tip and then release the ring. See Figure 3.
4. Be sure the tip is secure before starting to spray again.
5. Tip holding holes are provided on the chassis.

CAUTION

To avoid blowing the o-ring out of the quick coupler, due to the high pressure in the system, never operate the pressure washer without a tip securely mounted in the quick coupler.

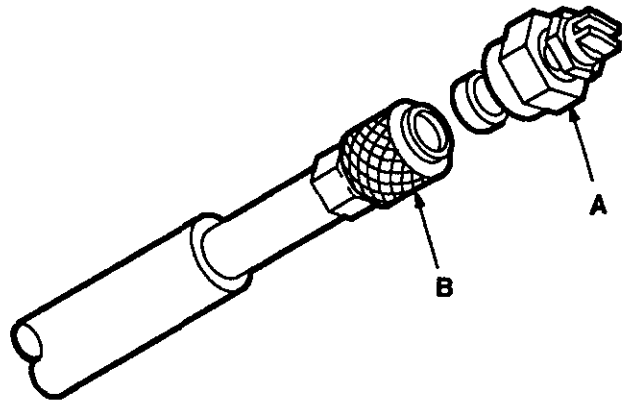

Figure 3

SHUTDOWN, FLUSHING AND STORAGE

WARNING

PRESSURE RELIEF PROCEDURE

To reduce the risk of serious bodily injury, including fluid injection and splashing in the eyes, or on the skin, always follow this procedure whenever you stop spraying for more than 10 minutes, when shutting down, and before checking or repairing any part of the system.

1. Engage the trigger safety latch.
2. Turn the sprayer off.
3. Disconnect the electrical supply.
4. Shut off the water supply.
5. Disengage the trigger safety latch and trigger the gun to relieve pressure, and then engage the trigger safety latch again.
6. Before long-term (overnight) storage, disconnect the water supply and disconnect the electricity.

1. If the pressure washer will be exposed to freezing temperatures, drain all water out of the pump. If it must be stored in freezing temperatures, flush the unit with a 50% anti-freeze solution. Relieve pressure. Flush the pressure washer before using it again to remove the anti-freeze.

CAUTION

If water does freeze in the pressure washer, thaw it in a warm room before trying to start it. **DO NOT** pour hot water on or into the pump; it may crack the ceramic plungers!

2. After each use, wipe all surfaces of the pressure washer with a clean, damp cloth.
3. Perform the appropriate maintenance. See the maintenance chart.

MAINTENANCE

Observing regular maintenance intervals helps ensure that you get maximum performance and life from the pressure washer.

There is a break-in period for the pump. After changing the oil initially, the interval between required changes is longer.

WARNING

To reduce the risk of serious bodily injury, including fluid injection, splashing in the eyes or on the skin or injury from moving parts, always follow the **Pressure Relief Procedure Warning** before proceeding.

Interval	What to do
Daily	Clean water inlet screen and filter. Check pump oil level. Fill as necessary.
After first 50 hours of operation	Change pump break-in oil. Use SAE 20 or 30 non-detergent oil.
Each 500 hours of operation or 6 months	Change pump oil. Use SAE 20 or 30 non-detergent oil.

TROUBLESHOOTING CHART

WARNING

To reduce the risk of serious bodily injury, including fluid injection, splashing in the eyes or on the skin, or injury from moving parts, always follow the **Pressure Relief Procedure Warning** before proceeding.

PROBLEM	CAUSE	SOLUTION
Low pressure and/or pump runs rough	Worn or wrong size tip. Inlet filter clogged. Worn packings, abrasives in water or natural wear. Inadequate water supply. Belt slippage. Fouled or dirty inlet or discharge valves. Even a small particle can cause the valve to stick. Restricted inlet. Worn inlet or discharge valves. Leaking high pressure hose.	Replace with tip of proper size. Clean. Check more frequently. Check filter. Replace packings. See PUMP SERVICE. Check water flow rate to pump. Unit must have a minimum 55 gallon float valve controlled water holding tank. Tighten or replace. Clean inlet and discharge valve assemblies. Check filter. Check garden hose, may be collapsed or kinked. Replace worn valves. Replace high pressure hose.
Water leakage from under pump manifold	Worn packings.	Install new packings. See PUMP SERVICE.
Water in pump	Humid air condensing inside crankcase. Worn packings. Oil seals leaking.	Change oil as specified in MAINTENANCE. Install new packings. See PUMP SERVICE. Install new oil seals. See PUMP SERVICE.
Frequent or premature failure of the packings	Scored, damaged or worn plungers. Abrasive material in the fluid being pumped. Inlet water temperature too high. Overpressurizing pump. Excessive pressure due to partially plugged or damaged tip. Pump running too long without spraying. Running pump dry.	Install new plungers. See PUMP SERVICE. Install proper filtration on pump inlet plumbing. Check water temperature; may not exceed 160°F. Do not modify any factory-set adjustments. See EQUIPMENT MISUSE HAZARD. Clean or replace tip. See Installing and Changing Spray Tips. Never run pump more than 10 minutes without spraying. Do not run pump without water.
Strong surging at the inlet and low pressure on the discharge side	Foreign particles in the inlet or discharge valve or worn inlet and/or discharge valves.	Clean or replace valves. See PUMP SERVICE.
Unit will not start	Unit not plugged in. Electrical service off/GFCI activated. Thermal overload has tripped.	Check power cord. Check fuse/circuit breaker. Check for proper grounding. Press reset button on motor for 1 phase units. Press stop button on the motor starter for 3 phase units.

PARTS DRAWING
800-900 Hydra-Clean® 3009 Pressure Washer
800-901 Hydra-Clean® 2510 Pressure Washer

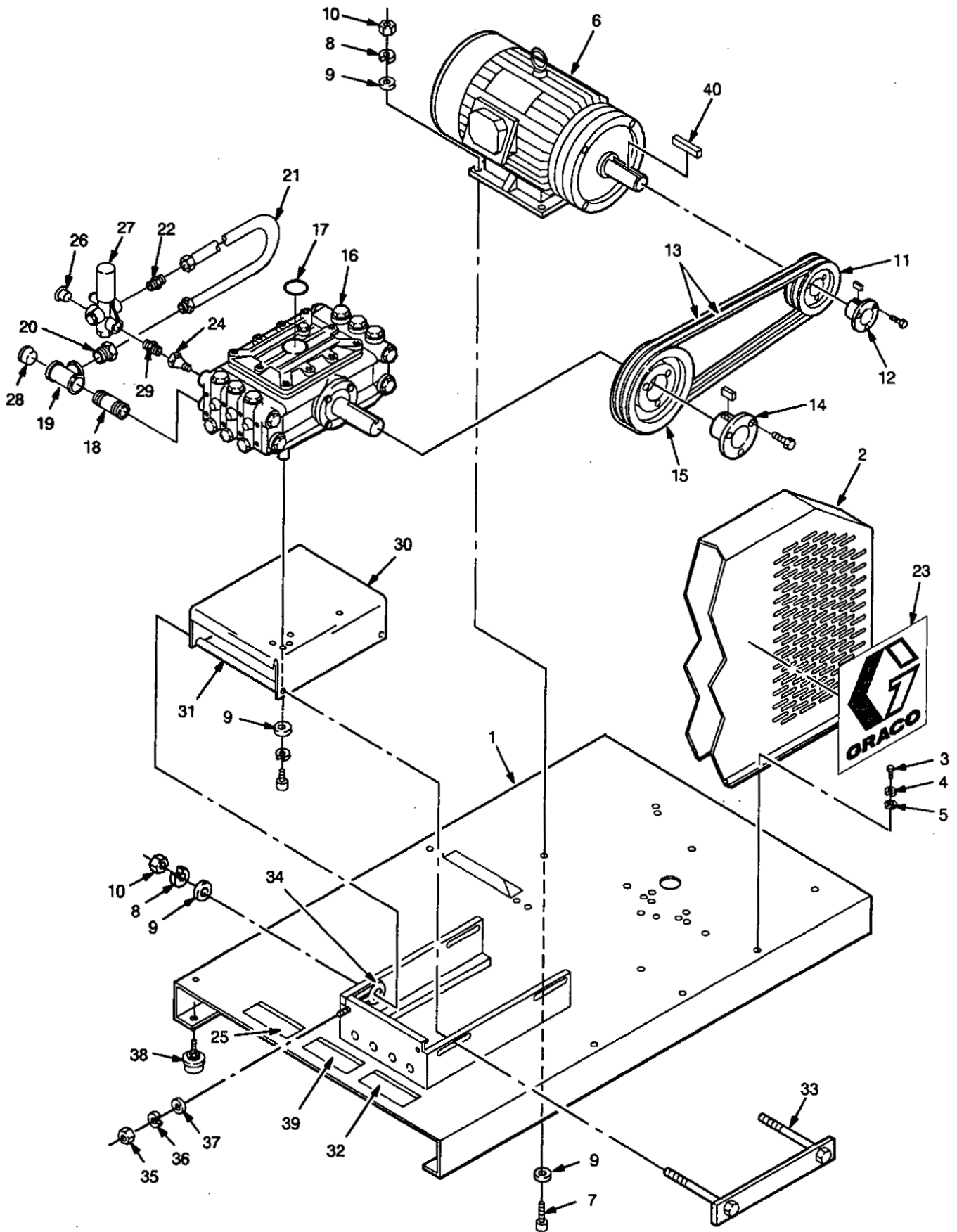

PARTS DRAWING

800-900 Hydra-Clean® 3009 Pressure Washer 800-901 Hydra-Clean® 2510 Pressure Washer

REF NO.	PART NO.	DESCRIPTION	QTY	REF NO.	PART NO.	DESCRIPTION	QTY
1	800-643	CHASSIS	1	20	802-096	BUSHING, Hex, 1/2 x 3/4	1
2	803-788	BELT GUARD	1	21	803-141	HOSE, Bypass	1
3	801-941	SCREW, Cap, hex hd., 5/16-18 x 1	6	22	802-534	NIPPLE, Hex 1/2 NPSM x 1/2 NPT	1
4	100-214	WASHER, Lock, 5/16	6	23	803-872	LABEL, Graco G	1
5	100-023	WASHER, Flat, 5/16	6	24	155-665	SWIVEL, 3/8 NPSM x 3/8 NPT	1
6	801-817	MOTOR, 20 hp, TEFC, 3 phase	1	25	803-396	LABEL, Warning	1
7	804-340	SCREW, Cap, hex hd., 1/2-13 x 2	4	26	803-790	CAP, 1/2	1
8	802-784	WASHER, Lock, 1/2	6	27	800-720	UNLOADER, 3000 PSI (for 800-900 only)	1
9	803-591	WASHER, Flat, 1/2	10		800-721	UNLOADER, 2500 PSI (for 800-901 only)	1
10	100-321	NUT, Hex, 1/2-13	6	28	803-791	CAP, 3/4	1
11	803-799	SHEAVE, Motor (for 800-900 only)	1	29	159-239	NIPPLE, Hex 1/2 x 3/8	1
	803-798	SHEAVE, Motor (for 800-901 only)	1	30	803-787	BRACKET, Pump	1
12	801-823	HUB, Motor	1	31	803-781	SUPPORT, Pump Bracket	2
13	803-809	BELT, Drive	2	32	176-250	LABEL, Warning, chassis	1
14	803-806	HUB, Pump	1	33	800-642	BRACKET, Rail Stiffener	1
15	803-796	SHEAVE, Pump	1	34	803-817	BOLT, Eye	2
16	803-814	PUMP, 9 GPM (for 800-900 only) See page 15	1	35	100-307	NUT, Hex 3/8-16	2
	803-790	PUMP, 10 GPM (for 800-901 only) See page 12	1	36	100-133	WASHER, Lock 3/8	2
17	803-517	LABEL, Keep From Freezing	1	37	100-132	WASHER, Flat 3/8	6
18	802-084	NIPPLE, 3/4 x 2	1	38	802-845	FOOT, Rubber	4
19	801-787	TEE, 3/4	1	39	172-981	LABEL, Warning, chassis	1
				40		KEY, Square 3/8 x 2-1/2	1

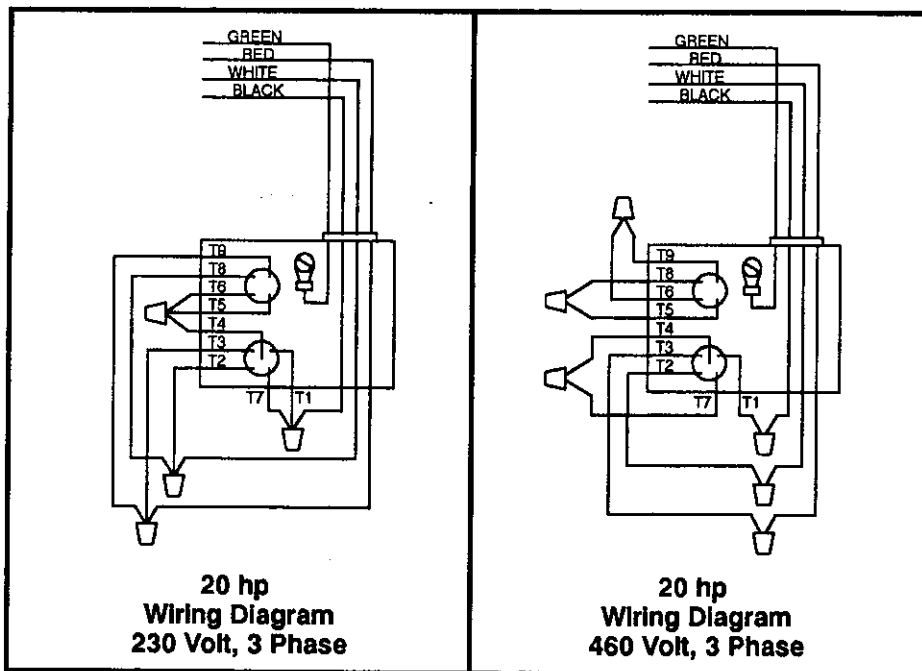

PARTS DRAWING

801-790 Pump Assembly, 2500 psi

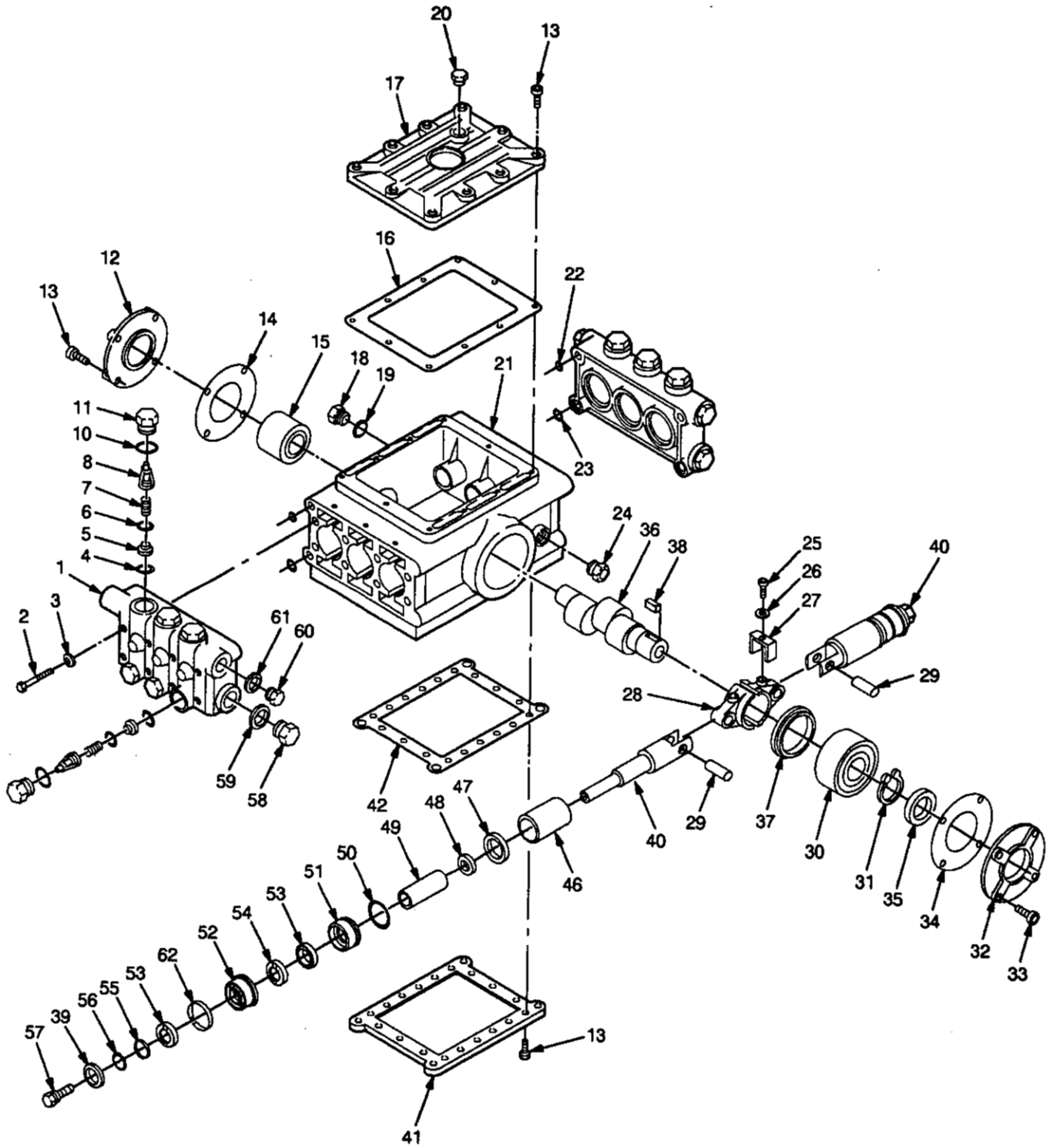

PARTS LIST

801-790 Pump Assembly, 2500 psi

REF NO.	PART NO.	DESCRIPTION	QTY	REF NO.	PART NO.	DESCRIPTION	QTY
1	801-781	MANIFOLD	2	32	803-418	COVER, Crankcase	1
2	801-468	SCREW, Cap, hex hd	16	33	803-283	SCREW, Cap, socket hd	4
3	801-469	WASHER, Lock	16	34	803-420	GASKET, Cover	1
4	Kit 1	O-RING		35	803-428	SEAL, Oil	1
5	Kit 1	SEAT, Valve		36	803-415	CRANKSHAFT	1
6	Kit 1	PLATE, Valve		37	803-426	RING, Connecting rod	6
7	Kit 1	SPRING, Valve		38	803-432	KEY	1
8	Kit 1	GUIDE, Valve		39	Kit 6	WASHER, Flat	
9	Kit 1	VALVE ASSEMBLY		40	803-417	GUIDE, Piston	6
10	Kit 4	O-RING		41	803-425	COVER, Crankcase	1
11	Kit 4	CAP		42	803-422	GASKET, Cover	1
12	803-419	COVER, Crankcase	1	44	802-304	WASHER, Lock	4
13	803-273	SCREW, Cap, socket hd	32	45	803-438	SCREW, Cap, socket hd	4
14	803-424	GASKET, Cover	1	46	803-431	BUSHING	6
15	803-433	BEARING, Tapered roller	1	47	Kit 24	SEAL, Oil	
16	803-423	GASKET, Cover	1	48	Kit 6	WASHER, Flinger	6
17	803-421	COVER, Crankcase	1	49	801-783	PLUNGER, Ceramic	6
18	802-793	CAP	1	50	Kit 29	O-RING	
19	801-488	O-RING	1	51	Kit 29	RETAINER, O-ring	
20	801-782	DIPSTICK	1	52	Kit 29	RING, Intermediate	
21	803-414	CRANKCASE	1	53	Kit 29 or 12	PACKING	
22	803-429	O-RING	4	54	Kit 29	RING, Head	
23	803-430	O-RING	4	55	Kit 6	RING, Backup	
24	802-345	GAUGE, Sight	1	56	Kit 6	O-RING	
25	803-437	SCREW, Cap, socket hd	6	57	Kit 6	SCREW, Piston	
26	803-435	WASHER, Lock	6	58	801-482	CAP	4
27	803-427	YOKE, Crankshaft	6	59	801-483	WASHER, Flat	4
28	803-416	ROD, Connecting	3	60	801-484	CAP	3
29	803-436	PIN, Wrist	6	61	801-485	WASHER, Flat	3
30	803-434	BEARING, Ball	1	62	Kit 29	RING, Long life	
31	802-357	RING, Snap	1				

Kit No.	Repair Kit Part No.	Ref No.	Description	Qty.
1	801-472 Valve	4	O-RING	6
		5	SEAT, Valve	6
		6	PLATE, Valve	6
		7	SPRING	6
		8	GUIDE, Valve	6
		9	VALVE ASSEMBLY	6
4	802-306 Valve Cap	10	O-RING	6
		11	CAP	6
6	801-474 Plunger Repair	39	WASHER, Flat	3
		48	WASHER, Flinger	3
		55	RING, Backup	3
		56	O-RING	3
		57	SCREW, Piston	3
12	801-769 Packing	53	PACKING	6
24	801-779 Oil Seal	47	SEAL, Oil	3
29	801-770 Packing & Retainer	50	O-RING	3
		51	RETAINER, O-ring	3
		52	RING, Intermediate	3
		53	PACKING	6
		54	RING, Head	6
		62	RING, Long life	3

PARTS DRAWING
803-814 Pump Assembly, 3000 psi

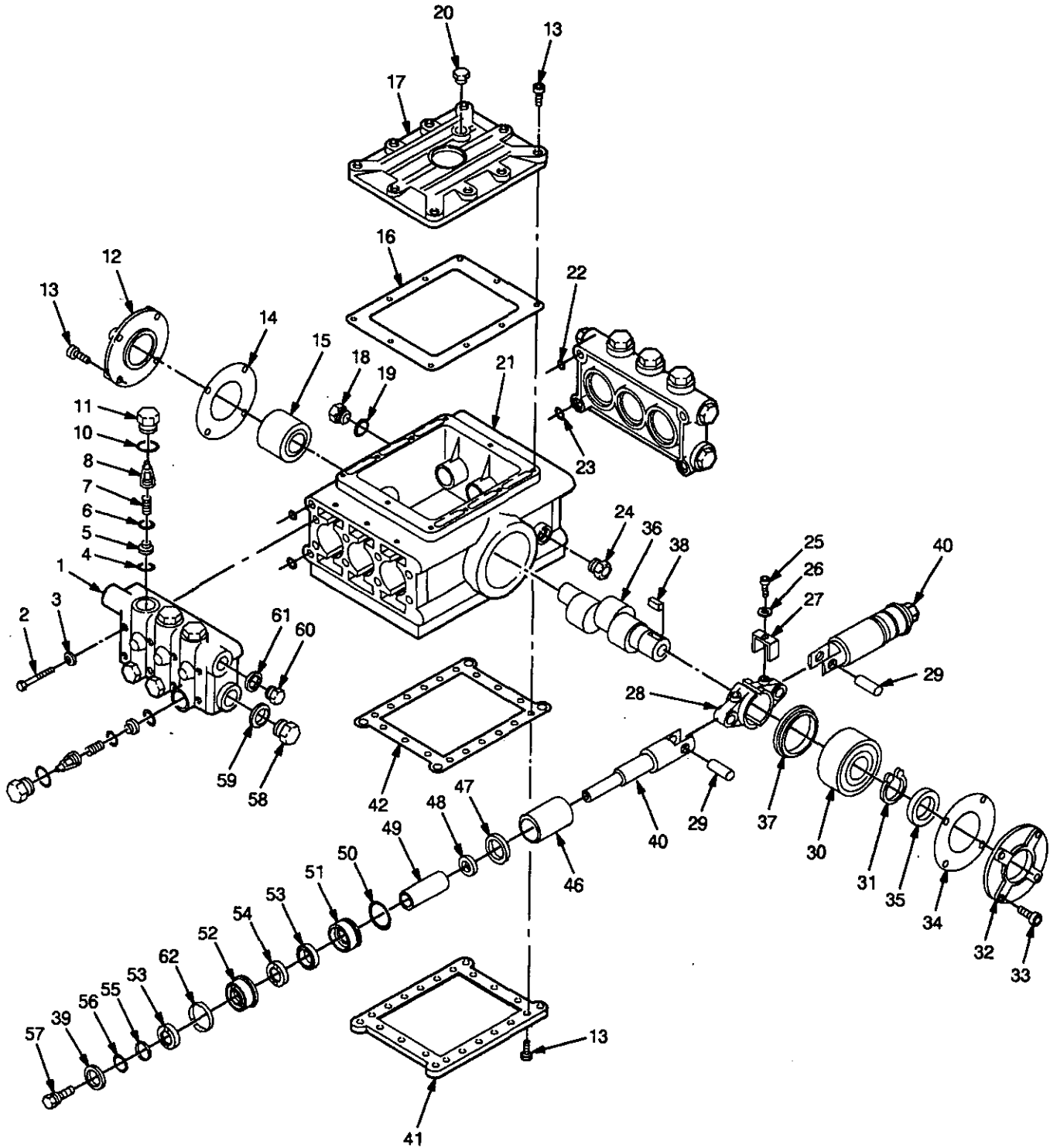

PARTS LIST

803-814 Pump Assembly, 3000 psi

REF NO.	PART NO.	DESCRIPTION	QTY	REF NO.	PART NO.	DESCRIPTION	QTY
1	801-781	MANIFOLD	2	32	803-418	COVER, Crankcase	1
2	801-468	SCREW, Cap, hex hd	16	33	803-283	SCREW, Cap, socket hd	4
3	801-469	WASHER, Lock	16	34	803-420	GASKET, Cover	1
4	Kit 1	O-RING		35	803-428	SEAL, Oil	1
5	Kit 1	SEAT, Valve		36	803-415	CRANKSHAFT	1
6	Kit 1	PLATE, Valve		37	803-426	RING, Connecting rod	6
7	Kit 1	SPRING, Valve		38	803-432	KEY	1
8	Kit 1	GUIDE, Valve		39	Kit 6	WASHER, Flat	
9	Kit 1	VALVE ASSEMBLY		40	803-417	GUIDE, Piston	6
10	Kit 4	O-RING		41	803-425	COVER, Crankcase	1
11	Kit 4	CAP		42	803-422	GASKET, Cover	1
12	803-419	COVER, Crankcase	1	44	802-304	WASHER, Lock	4
13	803-273	SCREW, Cap, socket hd	32	45	803-438	SCREW, Cap, socket hd	4
14	803-424	GASKET, Cover	1	46	803-431	BUSHING	6
15	803-433	BEARING, Tapered roller	1	47	Kit 24	SEAL, Oil	
16	803-423	GASKET, Cover	1	48	Kit 6	WASHER, Flinger	6
17	803-421	COVER, Crankcase	1	49	801-490	PLUNGER, Ceramic	6
18	802-793	CAP	1	50	Kit 28	O-RING	
19	801-488	O-RING	1	51	Kit 28	RETAINER, O-ring	
20	801-782	DIPSTICK	1	52	Kit 28	RING, Intermediate	
21	803-414	CRANKCASE	1	53	Kit 28 or 12	PACKING	
22	803-429	O-RING	4	54	Kit 28	RING, Head	
23	803-430	O-RING	4	55	Kit 6	RING, Backup	
24	802-345	GAUGE, Sight	1	56	Kit 6	O-RING	
25	803-437	SCREW, Cap, socket hd	6	57	Kit 6	SCREW, Piston	
26	803-435	WASHER, Lock	6	58	801-482	CAP	4
27	803-427	YOKE, Crankshaft	6	59	801-483	WASHER, Flat	4
28	803-416	ROD, Connecting	3	60	801-484	CAP	3
29	803-436	PIN, Wrist	6	61	801-485	WASHER, Flat	3
30	803-434	BEARING, Ball	1	62	Kit 28	RING, Long life	
31	802-357	RING, Snap	1				

Kit No.	Repair Kit Part No.	Ref No.	Description	Qty.
1	801-472 Valve	4	O-RING	6
		5	SEAT, Valve	6
		6	PLATE, Valve	6
		7	SPRING	6
		8	GUIDE, Valve	6
		9	VALVE ASSEMBLY	6
4	802-306 Valve Cap	10	O-RING	6
		11	CAP	6
6	801-474 Plunger Repair	39	WASHER, Flat	3
		48	WASHER, Flinger	3
		55	RING, Backup	3
		56	O-RING	3
		57	SCREW, Piston	3
8	801-486 Packing	53	PACKING	6
24	801-779 Oil Seal	47	SEAL, Oil	3
28	801-487 Packing & Retainer	50	O-RING	3
		51	RETAINER, O-ring	3
		52	RING, Intermediate	3
		53	PACKING	6
		54	RING, Head	6
		62	RING, Long life	3

PUMP SERVICE

WARNING

To reduce the risk of serious bodily injury, including fluid injection, splashing in the eyes or on the skin, or injury from moving parts, always follow the **Pressure Relief Procedure Warning** before proceeding.

NOTE: The following metric wrenches are needed: M10, M13 and M30. Repair kits are available. Refer to the individual repair sections and the pump parts page for more details. For the best results, use all parts in the kits.

NOTE: There are two different tool kits to aid in servicing the pump. P/N 800-298 is used to ease installation of packings. P/N 800-271 includes the items in 800-298 and tools to aid in the removal of packing retainers.

Valves

NOTE: For a set of six valves, order P/N 801-472.

1. Remove the hex plug from the manifold using an M30 wrench.
2. Examine the o-ring under the hex plug and replace it if it is cut or distorted.
3. Remove the valve assembly from the cavity; the assembly may come apart.
4. Install the new valve. Install the o-ring and hex plug; torque to 75 ft-lb (103 Nm).

NOTE: Retorque the plug after 5 hours of operation.

Pumping Section

1. Remove the eight capscrews and lockwashers from the manifold using an M13 wrench.
2. Carefully separate the manifold from the crankcase.

NOTE: It may be necessary to tap the manifold lightly with a soft mallet to loosen.

CAUTION

Keep the manifold properly aligned with the ceramic plungers when removing to avoid damage to the plunger or seals.

3. Carefully examine each plunger for any scoring or cracking and replace as necessary.

Servicing the Plungers

NOTE: Plunger repair kit, P/N 801-474 is available to replace retainers, o-rings, washers and backup rings for three cylinders.

1. Loosen the plunger retaining screw five to six turns, using an M10 wrench. Push the plunger towards the crankcase to separate the plunger and retaining screw.
2. Remove the screw from the plunger and examine the o-ring, backup ring and copper bearing/gasket washer. Replace these parts, if necessary, using kit 801-474.
3. Remove the plunger and flinger from the plunger shaft. Clean, examine and replace parts as necessary.
4. Inspect the plunger shaft for oil leakage from the crankcase. If leaking is obvious, replace the oil seals. Otherwise, DO NOT remove these seals as they cannot be reused. An oil seal kit is available to replace the seals.
5. Lightly grease the flinger and oil seal, if it is being replaced and replace them on the plunger shaft. Then install the plunger.
6. Lightly grease the retaining screw and the outer end of the plunger. Place the washer, o-ring and backup ring around the screw and install the screw through the plunger. Torque to 14.4 ft-lb (19.5 Nm).

NOTE: If you plan to replace the packings, refer to Servicing the V-Packings.

7. Lubricate the outside of each plunger. Slide the manifold onto the crankcase, being careful not to damage the seals.
8. Install the capscrews and washers finger-tight. Torque the screws to 21.7 ft-lb (29 Nm) following the tightening pattern (Figure 4). Uneven tightening may cause the manifold to bind or jam.

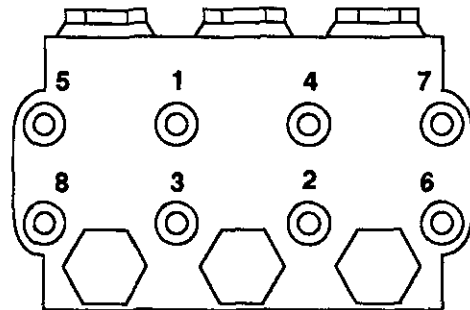

Figure 4

Servicing the V-Packings

NOTE: There are two types of packing kits: one is packings only, the other includes the packings, rings and retainers.

1. Remove the manifold as outlined in the Pumping Section.
2. Carefully pull the packing retainer from the manifold. Examine the o-ring and replace it if it is cut or damaged.
3. Remove the v-packing and head ring. Pull out the intermediate retainer ring. Remove the second v-packing and second head ring.
4. Inspect all parts and replace as necessary.

5. Thoroughly clean the packing cavities and examine for debris and damage.
6. Lightly grease the packing cavities and then replace the packings in the following order: head ring, v-packing, intermediate ring, head ring, v-packing and packing retainer with the o-ring installed in the retainer groove.

CAUTION

Install the parts in the proper order and facing the correct direction. Improperly installed parts will cause a malfunction.

7. Reassemble the manifold as instructed in Servicing the Plungers.

ACCESSORIES

(Must be purchased separately)

DOWNSTREAM CHEMICAL INJECTOR KIT
800-117 BRASS UP TO 5.5 GPM (21 LPM)
800-425 BRASS 5.6 TO 10.8 GPM (21 TO 41 LPM)
800-649 STAINLESS STEEL UP TO 5.5 GPM (21 LPM)

For injecting harsh cleaning chemicals downstream from the pump.

INLET PRESSURE REGULATOR 800-258

Regulates inlet water pressure to 60 psi (4 bar) maximum.

HOSE ASSEMBLY WITH QUICK COUPLERS **800-375**

3/8" diameter x 50 foot x 4000 psi (276 bar) permanently coupled hose with 801-568 and 801-569 3/8" quick couplers.

BACKFLOW PREVENTOR 801-133

Prevent back-up of contaminated water into fresh supply. Install upstream of pump.

GUN & WAND ASSEMBLY

800-392

Includes 803-350 spray gun, 32" spray wand and quick couplers for hose and spray tip connections.

800-398

Includes 803-350 spray gun, 32" spray wand, quick coupler for hose connection and adjustable nozzle.

800-398

Includes 803-222 stainless steel spray gun, 32" stainless steel spray wand and stainless steel threaded connections for hose and spray tip.

TECHNICAL DATA

	Model 800-901	Model 800-900
Motor (totally enclosed fan cooled)	20 HP, 3 phase	20 HP, 3 phase
Electrical Service	230 volt/50 amp/3 phase or 460 volt/25 amp/3 phase	230 volt/50 amp/3 phase or 460 volt/25 amp/3 phase
Water Pump Maximum Working Pressure	2500 psi (172 bar)	3000 psi (207 bar)
Water Pump Maximum Flow	10 gpm (38 lpm)	9 gpm (34 lpm)
Inlet Hose Connection	3/4" NPT (f)	3/4" NPT (f)
Weight	575 lbs (261 kg)	575 lbs (261 kg)
Dimensions		
Length	48" (1219 mm)	48" (1219 mm)
Width	30" (762 mm)	30" (762 mm)
Height	25" (635 mm)	25" (635 mm)
Maximum Inlet Water Temperature	160° F (70° C)	160° F (70° C)
Wetted Parts	<p>Acrylonitrile and Buna-N cover and tube</p> <p>Synthetic yarn and EPDM</p> <p>Anodized aluminum, Aluminum or bronze alloys, Brass Copper, Nylon-PTFE composite, Ceramic, Buna-N, Cotton phenolic, 303, 304, and 316 Stainless steel, Polyimide-12 thermoplastic, TPTFE carbon steel, Zinc with or without yellow chromate plate</p> <p><i>PTFE is a registered trademark of the DuPont Company.</i></p>	
High Pressure Hose		
Bypass Hose		
Pressure Washer (including fittings)		

THE GRACO WARRANTY

WARRANTY AND DISCLAIMERS

Graco warrants all equipment manufactured by it and bearing its name to be free from defects in material and workmanship on the date of sale by an authorized Graco distributor to the original purchaser for use. As purchaser's sole remedy for breach of this warranty, Graco will, for a period of twenty four months from date of sale, repair or replace any part of the equipment proven defective. This warranty applies only when the equipment is installed, operated and maintained in accordance with Graco's written recommendations.

This warranty does not cover, and Graco shall not be liable for, any malfunction, damage or wear caused by faulty installation, misapplication, abrasion, corrosion, inadequate or improper maintenance, negligence, accident, tampering, or substitution of non-Graco component parts. Nor shall Graco be liable for malfunction, damage or wear caused by the incompatibility with Graco equipment of structures, accessories, equipment or materials not supplied by Graco, or the improper design, manufacture, installation, operation or maintenance of structures, accessories, equipment or materials not supplied by Graco.

This warranty is conditioned upon the prepaid return of the equipment claimed to be defective for examination by Graco to verify the claimed defect. If the claimed defect is verified, Graco will repair or replace free of charge any defective parts. The equipment will be returned to the original purchaser transportation prepaid. If inspection of the equipment does not disclose any defect in material or workmanship, repairs will be made at a reasonable charge, which charges may include the costs of parts, labor and transportation.

DISCLAIMERS AND LIMITATIONS

THE TERMS OF THIS WARRANTY CONSTITUTE THE PURCHASER'S SOLE AND EXCLUSIVE REMEDY AND ARE IN LIEU OF ANY OTHER WARRANTIES (EXPRESS OR IMPLIED), INCLUDING WARRANTY OF MERCHANTABILITY OR WARRANTY OF FITNESS FOR A PARTICULAR PURPOSE, AND OF ANY NON-CONTRACTUAL LIABILITIES, INCLUDING PRODUCT LIABILITIES, BASED ON NEGLIGENCE OR STRICT LIABILITY. EVERY FORM OF LIABILITY FOR DIRECT, SPECIAL OR CONSEQUENTIAL DAMAGES OR LOSS IS EXPRESSLY EXCLUDED AND DENIED. IN NO CASE SHALL GRACO'S LIABILITY EXCEED THE AMOUNT OF THE PURCHASE PRICE. ANY ACTION FOR BREACH OF WARRANTY MUST BE BROUGHT WITHIN THREE (3) YEARS OF THE DATE OF SALE.

EQUIPMENT NOT COVERED BY GRACO WARRANTY

GRACO MAKES NO WARRANTY, AND DISCLAIMS ALL IMPLIED WARRANTIES OF MERCHANTABILITY AND FITNESS FOR A PARTICULAR PURPOSE, WITH RESPECT TO ACCESSORIES, EQUIPMENT, MATERIALS OR COMPONENTS SOLD BUT NOT MANUFACTURED BY GRACO. These items sold, but not manufactured by Graco (such as electric motor, switches, hose, etc.) are subject to the warranty, if any, of their manufacturer. Graco will provide purchaser with reasonable assistance in making any claim for breach of these warranties.

IMPORTANT PHONE NUMBERS

TO PLACE AN ORDER, contact your Graco distributor, or call this number to identify the distributor closest to you: **1-800-328-0211 Toll Free**

FOR TECHNICAL ASSISTANCE, service repair information or assistance regarding the application of Graco equipment: **1-800-543-0339 Toll Free**

Factory Branches: Atlanta, Chicago, Dallas, Detroit, Los Angeles, West Caldwell (N.J.)
Subsidiary and Affiliate Companies: Canada; England; Switzerland; France; Germany; Hong Kong; Japan; Korea

GRACO INC. P.O. BOX 1441 MINNEAPOLIS, MN 55440-1441

PRINTED IN U.S.A. 308-535 4/91